

Installation scheme

## 1. Dimensions for installation scheme – table 1

Type	Standard length L mm	Support spacing L <sub>1</sub> for		Extending length L <sub>2</sub> mm	Air gap L <sub>3</sub> mm	Extending length L <sub>4</sub> mm
		Straight tracks and lateral curves	Horizontal curves*			
U 20	6000	1000	thru R <sub>HT</sub> = 5m: 500mm	200	max. 8	100
U 30	6000	1500	thru R <sub>H</sub> = 10m: 750mm	400	max. 10	140
U 40	6000	2000	thru R <sub>H</sub> = 15m: 1000mm	400	max. 12	130

\* Larger horizontal radius bends will require the same support spacing as straight runs.

### Note:

Always follow the layout plan which will be provided for systems with curves, transfers, isolating sections etc.

## 2. Symbols in layout plans

	Crane track	
	Conductor rail	
	Rigid joint	UV, UVB
	Expansion joint	UDV
	Locating clamp	USK
	Feed terminal (power)	UE, UEV, UEVG
	Feed terminal (control)	UEN, UES
	End cap	UK
	Isolating section	IT/U
	Hanger	UAM, UA, UAK, UIM, UAS, KA, KH
	Insulator	GH, GHH, UIK
	Transfer funnel multi-pole	EM, EMK
	Transfer guide	US, UTI

## 3. Support brackets

Spacing between conductors see table 2 below

Conductor arrangement	U 20	U 30	U 40
Rail joints side by side	50	80	130
Rail joints and collectors staggered	40	50	100
For transfer applications one-pole	65	200	270
multipole	40	80	130
With compact hangers KH	26	50	—
With compact hangers KA	23	50	—

Always stagger joints and power feeds for compact systems and make sure that joints do not coincide with hangers.

First hanger per table 1 (L<sub>2</sub>).

## 4. Insulated hangers and insulators with rail holders (photo 1)

Secure hangers or insulators with rail holders to brackets. Slide conductor bars into hangers or rail holders.

### Important:

Perpendicular position and alignment with conductors to allow for expansion and contraction.



Photo 1: 4-pole conductor arrangement

## 5. Compact hangers for U 20 and U 30

### Compact hanger KA (photo 2)

- holes Ø 7 mm for U 20 and holes Ø 9 mm for U 30 must be prepared in the I-beam or other track
- bolt compact hangers securely, whereby slotted holes require flat washers on both sides of brackets

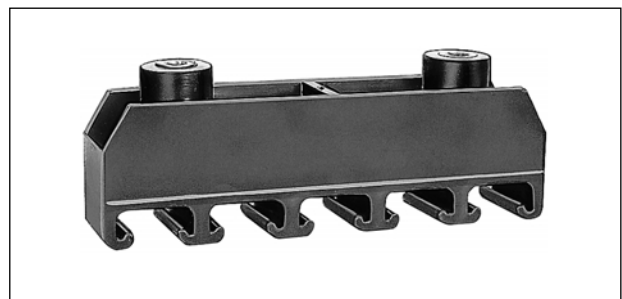

Photo 2: Compact hanger KA 20/5



Reg. No. 3140





# INSTALLATION PROCEDURE FOR U 20, 30, 40

## Compact hanger KH (photo 3)

- bolt or weld bracket profiles 38/17 (photo 4) to the track
- push compact hangers into brackets and set locating pins
- make sure that position of brackets is in level and rectangular to the track.

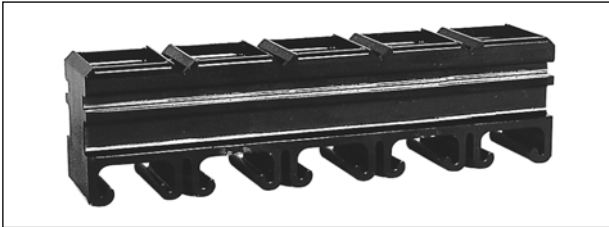

Photo 3: Compact hanger KH 20/5

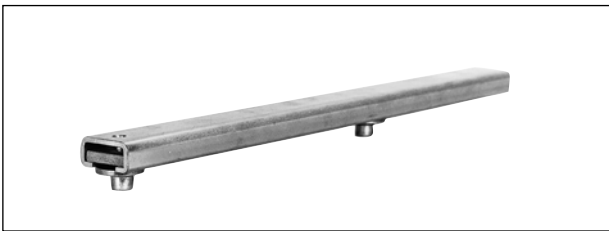

Photo 4: Bracket profile 38/17

## 6. Conductors and splice joints

Conductor bars are rigidly connected by bolted joints. All conductor rail sections come ready prepared for joints. Rework the rail ends per 6.1. instructions whenever you have to cut/adjust in the field. Make sure that joints are clean of any residue; light greasing is required:

- polishing with Scotch Brite
- Remove grinding residues (compressed air, lint-free cloth, etc.)
- Apply contact grease (directly after cleaning)

Do not leave a gap between conductor ends. Tighten all bolts.

### U 20 and U 40:

Assemble and bolt together insulated protection joint covers (photo 5). Make sure that cover fit accurately in the grooves of the conductor bar shrouding.

### U 30:

Assemble joint cover halves from the sides to the conductor bar joint. Press the two halves together until they interlock. Tighten cover bolts.

### U 20, U 30 and U 40:

Slight height variations of the conductor profile are possible due to production tolerances. Smooth-out joints where necessary.

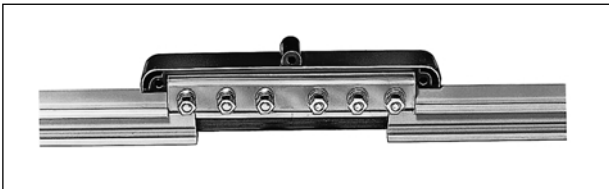

Photo 5: Bolted rigid joint

### 6.1 Preparing of short lengths

If short lengths have to be made at site prepare conductor ends as follows:

- Mark conductor length, cut it and trim conductor ends.

- push back conductor w/i shrouding cut shrouding by  $2 L_3$  and trim cut ends.
- For U 20 and U 40 prepare additional recess in the shrouding with length  $L_2$  and trim cut ends.

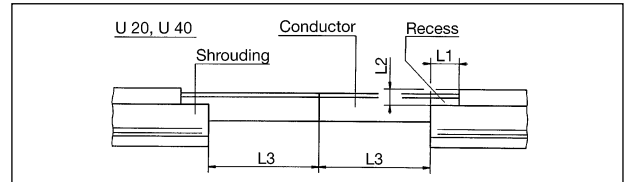

Sketch a

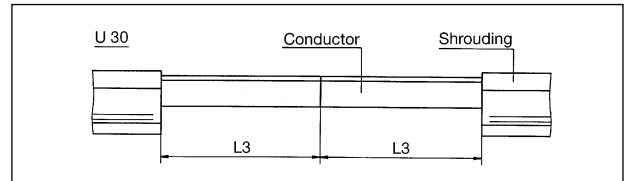

Sketch b

Table 3

Type	Dimension $L_1$	Dimension $L_2$	Dimension $L_3$
U 20	31	7	2
U 30	-	-	102
U 40	20	13	78

- reset copper conductor and place it equally within shrouding.

## 7. Expansion sections

Expansion joints come ready assembled on conductor rail sections.

Expansion joints will be required for:

1. Lengths exceeding 100 meters, in approx. 42 m intervals.  
Make sure you have an anchor point in the center between two expansion joints or between an expansion joint and the end of the system run (see sketch c).

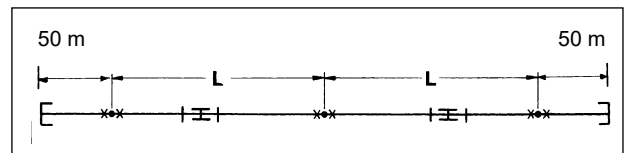

Sketch c

2. Conductor lengths between two curves, switches or other fix points exceeding 20 meters (see sketch b).

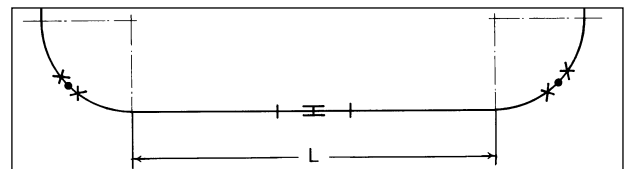

Sketch d

Furthermore dimension L depends on the temperature difference ( $\Delta t$ ):

Table 4

max. $\Delta t$	max. L		max. $\Delta t$	max. L	
	U 20	U 30/U 40		U 20	U 30/U 40
20 °C	88 m	100 m	40 °C	44 m	50 m
30 °C	58 m	68 m	50 °C	35 m	40 m

# INSTALLATION PROCEDURE FOR U 20, 30, 40



Expansion joints compensate max.:

U 20 = 30 mm      U 30 = 35 mm      U 40 = 35 mm

To determine the adjustable airgap of the expansion joint proceed as follows:

- Mark lowest and highest anticipated temperature in Sketch e and connect the two points.
- Indicate the ambient temperature during installation and compute dimension »a« from the chart.

Sketch e

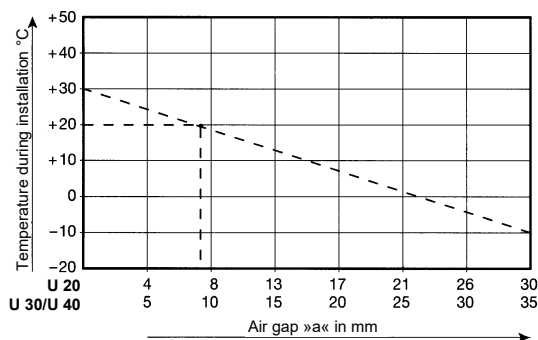

Example: max. ambient = + 30° C }  $\Delta t = 40^\circ$   
 min. ambient = - 10° C } C  
 during installation = 20° C  
 dimension »a« = 7 mm for U 20  
 = 8 mm for U 30/U 40

– Set expansion joint with appropriate gap.

## 8. Locating clamps (photo 6)

Locating clamps are required to avoid unwanted sliding of conductors. Two locating clamps, left and right of a hanger make up an anchor point.

Where to provide anchor points:

In case of short straight runs – in the center (see sketch below)

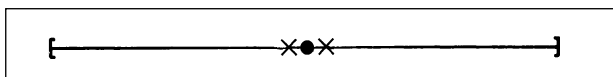

Sketch f

In bends, as well as in areas of switches, drop sections etc. – see sketch below.

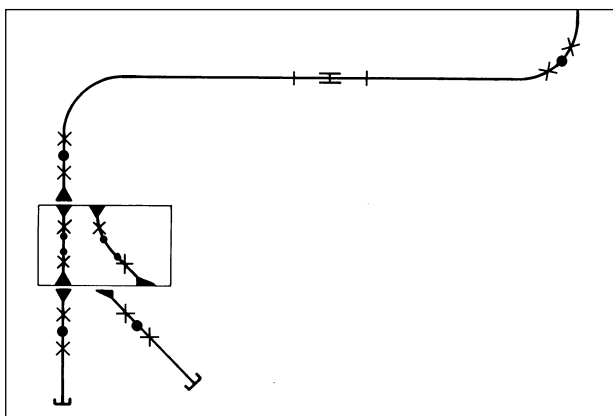

Sketch g

Check shroud opening after tightening locating clamps (see photo 6, dim. a)

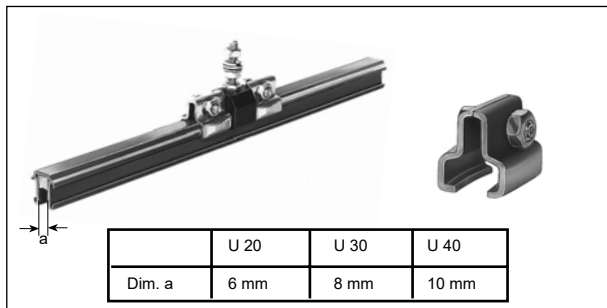

Photo 6: Fixpoint (insulated rail holder with 2 locating clamps)

## 9. Feeds (photo 7)

The feeds are preferably set between two bars, taking the position of the rigid joint near existing power supply (U 20 and U 30 type UE, U 40 type UEV, UEVG).

Treatment of contact surfaces and further mounting as per item 6.

Feed cables must not restrict free movement of conductors and must give clearance for the collectors passing through. Provide tension relief for cable.

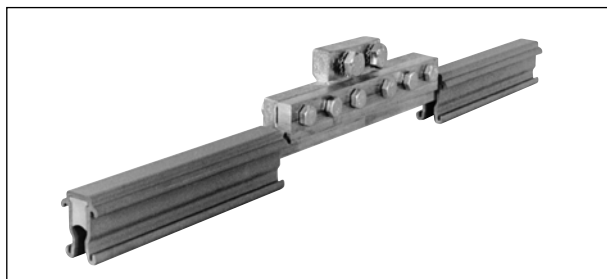
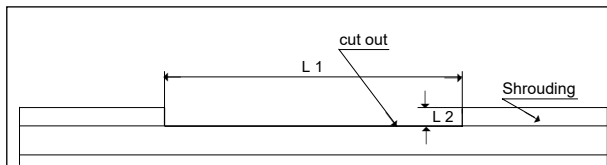

Photo 7: Feed terminal UEV 30 without cap

### Procedure for assembling of feed terminals on conductor sections U 20 and U 40:

- Slide shrouding over the conductor as per sketch a
- Mark position of feeding on the conductor rail
- Pull off shrouding from conductor and cut out at the marked position (sketch h), trim cut areas of shrouding and push it back onto the conductor
- Treatment of contact surfaces and further mounting as per item 6



Sketch h

Table 5

Type	Dimension L1	Dimension L2
U 20	62	7
U 30 (UEG)	196	11
U 40	196	13

### U 30:

- Slide shrouding over the conductor as per sketch b
- Mark position of feeding on the conductor rail
- Pull off shrouding from conductor and make a vertical cut at the marked position
- Shorten shrouding in this place by 102 mm each side, trim ends and push shroudings back onto the conductor
- Treatment of contact surfaces and further mounting as per item 6



# INSTALLATION PROCEDURE FOR U 20, 30, 40

## 10. Isolating sections

These sections provide electrical interruption (discontinuous circuits) in the conductor line.

They normally come factory assembled per layout plan; for field assembling consider the following:

Mark the desired position on a conductor rail section.

Pull out conductor and cut at the marking point, the length you cut away depends on the type of rail-dead-section you are using.

Insert the isolating piece and the two conductor lengths into the shrouding.

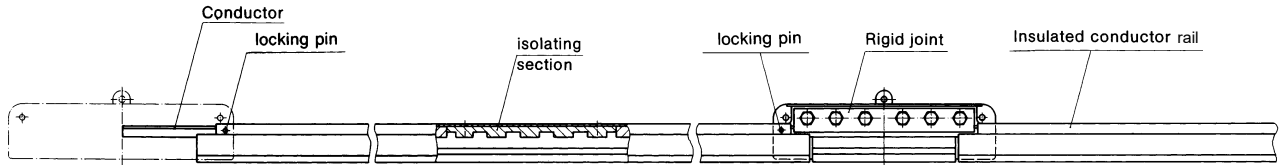

Prepare  $\varnothing 3$  DIN 1481 fix points at the bar-ends as shown below (locking pins).

Multi-pole systems require an accurate side by side position of the isolating sections.

An additional hanger on each side of the isolating section must be provided for stability.

(One hanger each side at max. 200 mm for U 20, 300 mm for U 30, 400 mm for U 40).

## 11. Transfer guides (photo 8)

These units are mainly required for switch and drop section applications.

Installation:

Conductor U 20 and U 30 will be cut straight; sand paper where necessary. Push type US transfer guide over the end and secure tightly.

Type UTI transfer guides always come factory assembled.

Max. vertical and horizontal offset:

	U 20 $\pm 2$ mm
	U 30 $\pm 4$ mm
	U 40 $\pm 6$ mm

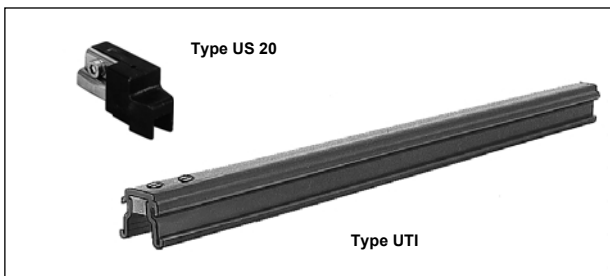

Photo 8: Transfer guide

## 12. Transfer funnel (photo 9)

These transfer funnels come factory assembled with conductor sections to meet your system layout.

Make sure the transfer funnel is fastened to a non-vibrating support structure.

Consider proper alignment for re-tracking your collectors. These transfer funnels serve for any length of conductor rail interruption.

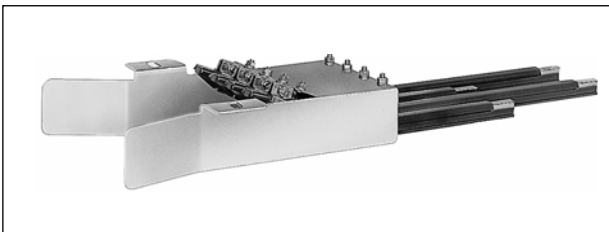

Photo 9: Transfer funnel

## 13. End caps (photo 10)

The end caps are closing the conductor rail ends and are secured by means of nylon screws.

In case you have to field cut the end conductor bar make sure that you are securing the shrouding with a locking pin  $\varnothing 3$  DIN 1481 before assembling the end cap.

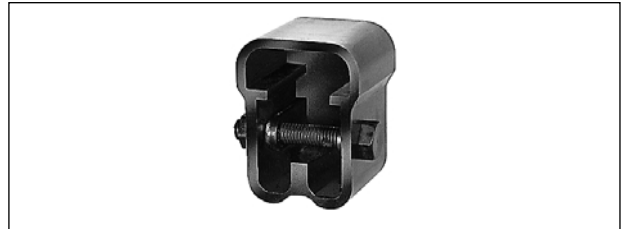

Photo 10: End cap

## 14. Bending of conductor rails

All insulated conductor rails can be bent. Field bending of U 20 with radius  $> 2500$  mm smaller radii and U 30 and U 40 curves are available on request from the factory.

**Bending procedure:**

– Install hangers.

Push or press conductor rails into the hangers and the flexibility of the conductors allows to follow the required curve. Small support intervals for curves guarantee a proper layout without kinking.

– Check the entry slot of the shrouding. It should be

U 20 = 6 mm  $\pm 1$

U 30 = 8 mm  $\pm 1$

U 40 = 10 mm  $\pm 1$

## 15. Collectors:

Collectors for U 20 and U 30 conductors are square bar mounted. The triangular attachment is prepared for the ground collector.

Weld the square bar bracket to the moving equipment, rectangular and in level with conductors. Consider the normal working heights of the collectors.



All collectors for U 40 conductors are for bolt mounting (M 16). Stud spacing for phase collectors is 70 mm, for ground collectors 120 mm.

Specially balanced and re-tracking collectors are available for transfer applications. Always make sure that the collector shoe is in parallel with the conductor rails and entering transfer funnels slightly (min. 20 mm) beneath the top part of these guides.

## 16. Commissioning and final check-up:

Make test runs; start with low speed and inspect all components for proper function. Check positive contact between pick up shoes and conductors – no vibration of collectors and no sparking. In case of sparking clean conductor contact surface.

All transfer applications require special attention for proper passing over and re-tracking of collectors.

## 17. Maintenance instructions:

VAHLE unipole insulated conductor rail systems require a minimum of maintenance.

- 1) Visual inspection of conductors and collectors in regular intervals, depending on the duty cycle. Consult factory in case of irregularities.
- 2) Collector shoes must be replaced prior to the brush holder touches the conductor shrouding.
- 3) Transfer funnels require replacement of the isolating cover, if collector trackings are 2–2.5 mm deep.
- 4) If cleaning of the conductor surface becomes necessary we recommend:
  - a) Cleaning with high pressure water stream
  - b) Cleaning with liquid Rivolta SRK.  
Use a flat brush or impregnated felt, dry the cleaned surfaces afterwards.

---

## Hints for the Installation Procedure:

Proper and careful treatment of all materials, especially the non-metallic parts, keeping everything clean etc. is important. Make sure, that joints and all other connecting points are clean of any residue. Tighten all hardware, using lockwashers etc. carefully. Take care of proper alignment between conductor rails and crane runway.

Install conductor rails in accordance to appertaining layout plans. Make sure that position of expansion joints and locating clamps is exactly per drawing and/or catalog instructions.

---

## Safety Regulations for work with electrical equipment:

1. Disconnect mains
2. Prevent reconnection
3. Test for absence of harmful voltages
4. Ground and short circuit
5. Cover or close off nearby live parts

To energize, apply in reverse order.



# INSTALLATION PROCEDURE FOR U 20, 30, 40

## Copper-graphite brushes for U 20

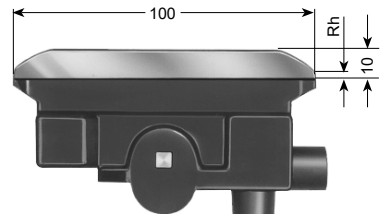
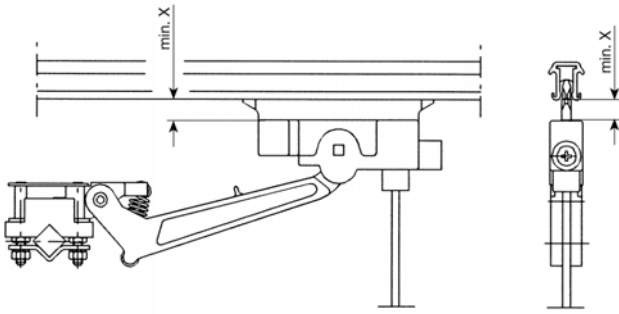

KMK 60 / KMK 60 U

Conductor Type	Reference dim. X	Remaining height = Rh brush type KMK 60 / KMK 60 U
U 20/50 AF	3,5	2
U 20/50 CE		
U 20/50 AC		
U 20/50 C		
U 20/50 CH		

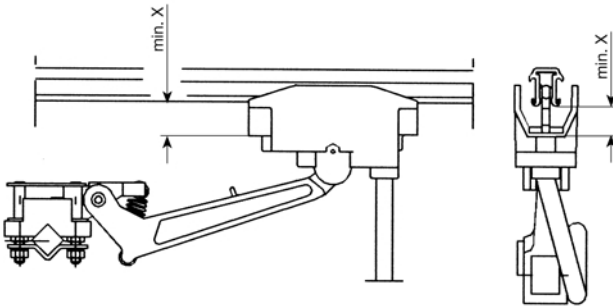

KMU 40 / KMU 60

Conductor Type	Reference dim. X	Remaining height = Rh brush type KMU 40 / KMU 40 U KMU 60 / KMU 60 U
U 20/50 AF	8	20
U 20/50 CE		
U 20/50 AC		
U 20/50 C		
U 20/50 CH		



KMU 40 / KMU 60 U

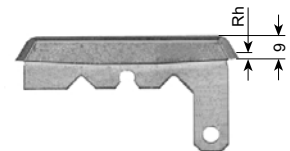
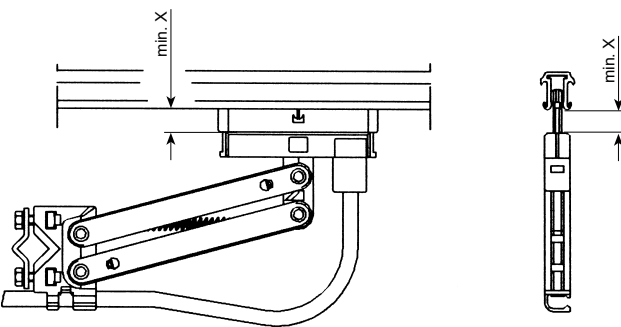

KM 55 phase / ground

Conductor Type	Reference dim. X	Remaining height = Rh brush type KM 55
U 20/50 AF	3	0
U 20/50 CE		
U 20/50 AC		
U 20/50 C		
U 20/50 CH		

# INSTALLATION PROCEDURE FOR U 20, 30, 40



## Copper-graphite brushes for U 30

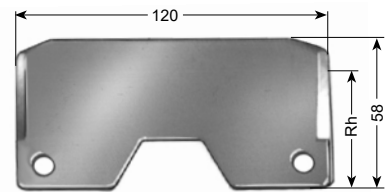
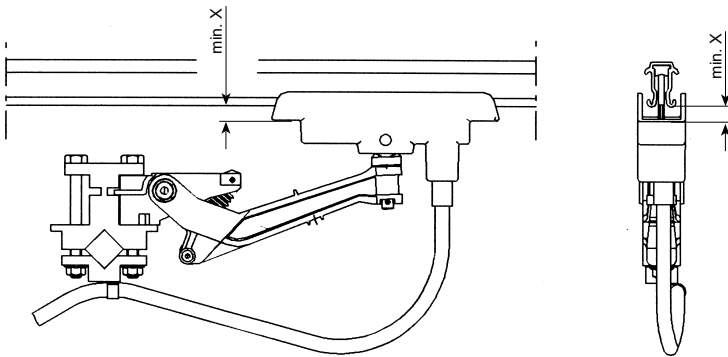

KMK 100/30

Conductor Type	Reference dim. X	Remaining height = Rh brush type	
		KMK 100/30	KMK 140/30
U 30/125 AC	9	47	9
U 30/225 AC		43	6
U 30/120 CE		53	16
U 30/ 75 C		47	10
U 30/100 C		54	17
U 30/130 CH		54	17
U 30/150 C		50	13
U 30/200 C		46	9
U 30/200 CH		48	11

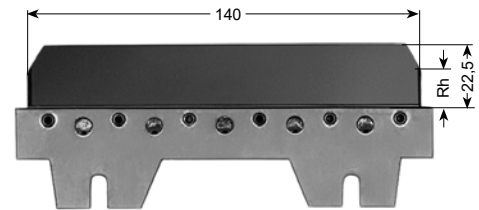

KMK 140/30

## Copper-graphite brushes for U 40

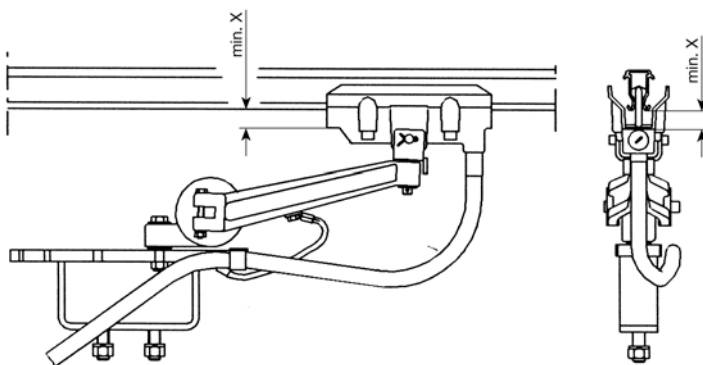

Conductor Type	Reference dim. X	Remaining height = Rh brush type KMU 200
U 40/200 C	20	
U 40/400 C		
U 40/300 C	25	
U 40/400 CH		
U 40/300 CH	19	
U 40/500 CH	18	
U 40/500 C	15	
U 40/500 CHH	12	



KMU 200



Reg. No. 3140

## Catalog No.

Copperhead Conductor Systems	1 a
Battery Charging Systems	1 b
Insulated Conductor Systems U 10	2 a
Insulated Conductor Systems U 20 - U 30 - U 40	2 b
Insulated Conductor Systems U 15 - U 25 - U 35	2 c
Aluminium Enclosed Conductor Systems	3 a
Steel Enclosed Conductor Systems	3 b
Powerail Enclosed Conductor Systems KBSL - KSL - KSLT - KSG	4 a
Powerail Enclosed Conductor Systems VKS - VKL	4 b
Powerail Enclosed Conductor System MKL	4 c
Heavy Enclosed Conductor Systems	5
Trolley Wire and Accessories	6
Cable Tenders	7
Cable Carriers for □-tracks	8 a
Cable Carriers for Flatrom Cable on I-beams	8 bF
Cable Carriers for Round Cable on I-beams	8 bR
Cable Carriers for ◇-tracks	8 c
Conductor Cables and Fittings	8 L
Spring Operated Cable Reels	9 a
Overload Protection Systems	9 b
Powercom® Data Transmission Systems	9 c
CPS - Contactless Power Supply	9 d
SMG - Slotted Microwave Guide	9 e
Motor Powered Cable Reels	10

**VAHLE**   
**ELECTRIFICATION SYSTEMS**